



SAFETY AT THE HIGHEST LEVEL

The Safety Solution for Free Standing Roof Edge Protection



- PROVIDES COLLECTIVE PROTECTION FOR ALL ROOF TOP WORKING
- MEETS THE REQUIREMENTS OF THE 'WORKING AT HEIGHTS' LEGISLATION
- COMPLIES WITH EN ISO 14122 PART 3 AND EN 13374 CLASS A
- RECYCLED PVC WEIGHTS ENSURE NO PENETRATION OF THE ROOF SURFACE



FM36179

Why You Need Fall Protection?

In the UK, according to the Health and Safety Executive (HSE), falls from height are the biggest cause of death and the second biggest cause of serious injuries in the workplace. Every day contractors require regular access to rooftops to carry out essential building, repair and maintenance work.

Under the amended Work at Height Regulations 2007, it is the moral duty and legal responsibility of those in control of rooftop work to do all that is reasonably practical to prevent anyone falling. Companies whose business involves working at height have to ensure they provide suitable safety equipment and have appropriate procedures in place before allowing their staff to work in potentially dangerous situations.

By using correctly installed and tested fall protection systems you can ensure the safety of anyone who has to access a roof.



As a leading supplier of both Collective and Personal Protection products Kee Safety has a portfolio which can eliminate many of the unnecessary risks that are still taken every day by people working at heights.



**Kee®
Guard**

KeeGuard® Free Standing Roof Edge Protection



KEEGUARD is a modular free standing roof edge protection system that has been fully tested and approved which does not penetrate the roof membrane. By using a correctly installed and tested **KEEGUARD** system you can ensure the safety of anyone who has access onto a flat roof.

Easy to handle, recycled PVC weights provide stability and galvanised **KEE KLAMP** fittings and tube complete the system. **KEEGUARD** is supplied in prefabricated kit form with a minimum number of assemblies which allows for ease of installation. It is a safe, versatile system which delivers reliable collective protection.



**Kee®
Guard**

Free standing non-penetrative roof edge protection, galvanised steel.



**KeeGuard®
Lite**

Free standing non-penetrative roof edge protection, lightweight aluminium.



**KeeGuard®
Foldshield**

Free standing non-penetrative roof edge protection, foldable to protect buildings aesthetics and easily re-erected when required. Available in galvanised steel or with aluminium top and mid rails.



**KeeGuard®
Topfix**

Collective protection solution for metal profile and standing seam roofs, utilises a standard base plate with multiple fixing centres. Available in both galvanised steel and aluminium options.

The KeeGuard® System

Kee®
Guard



Durability and Simplicity

- Corrosion resistant - all iron fittings are galvanised to EN ISO 1461
- Fittings use case hardened steel setscrews with **KEE KOAT** protection
- Minimum components for ease of installation
- Modular design allows reconfiguration on site if needed
- Sections can be added to or taken down, for reconstruction elsewhere
- Unique open style fitting allows quick installation of horizontal rails
- Three types of upright available (see page 5)
- No penetration of the roof membrane
- No welding, threading or bolting required on site
- Can be colour coated to any RAL colour
- Installation can be customised to cope with ladder access and any other fixed rooftop obstructions.

Setting the Standards

When correctly designed and installed, **KEEGUARD** will meet or exceed the following safety requirements:

- EN ISO 14122 Part 3
- EN 13374 Class A
- HSG-33 Health & Safety in Roof Work
- HSE INDG 284 "Working on roofs"
- BS 6399: Part 2 1995 Wind Code.

Safety and Versatility

- System works on a proven counterbalance system
- Suitable for use on concrete, asphalt, PVC membrane and felt roof surfaces
- Compatible with almost all configurations of flat roofs up to 10 degrees slope
- Integral toeboard fixings
- Assemblies are fitted with anti-slip pads
- Design load: 300 N/m applied horizontally along the top rail
- Coloured cover strip available for counterbalance tube to reduce trip hazard.



A Typical KeeGuard® Configuration when Secondary Restraint is Available

KEEGUARD free standing roof edge protection system meets the requirements of EN 14122 pt. 3 by use of sufficient counter-weight restricting the movement of the guard rail in the event it being called into use. Where a parapet (minimum height 150mm) is in place which can help to absorb some of the force applied against the rail the following configuration can be used.

The bay lengths are 2.2 metres and the free ends require two weights per free end.

If the end bay length is reduced to 1.5m, only one weight is needed per free end.

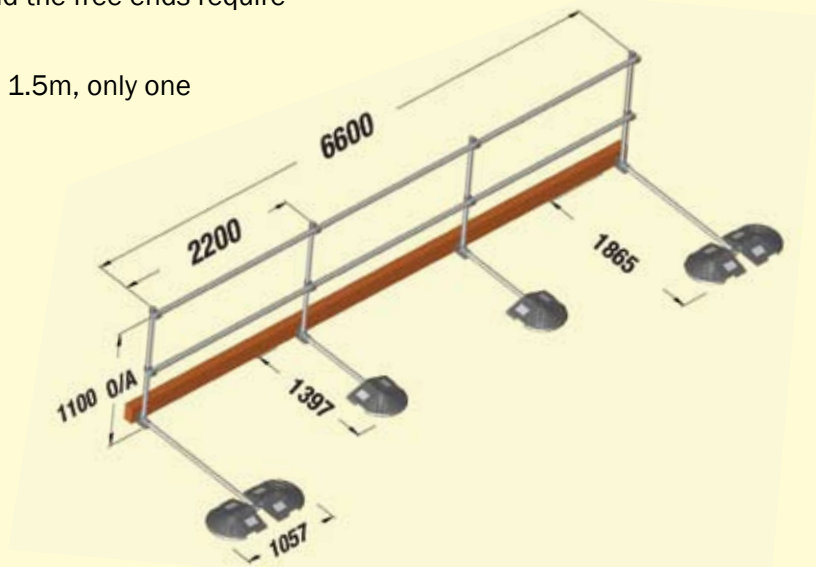



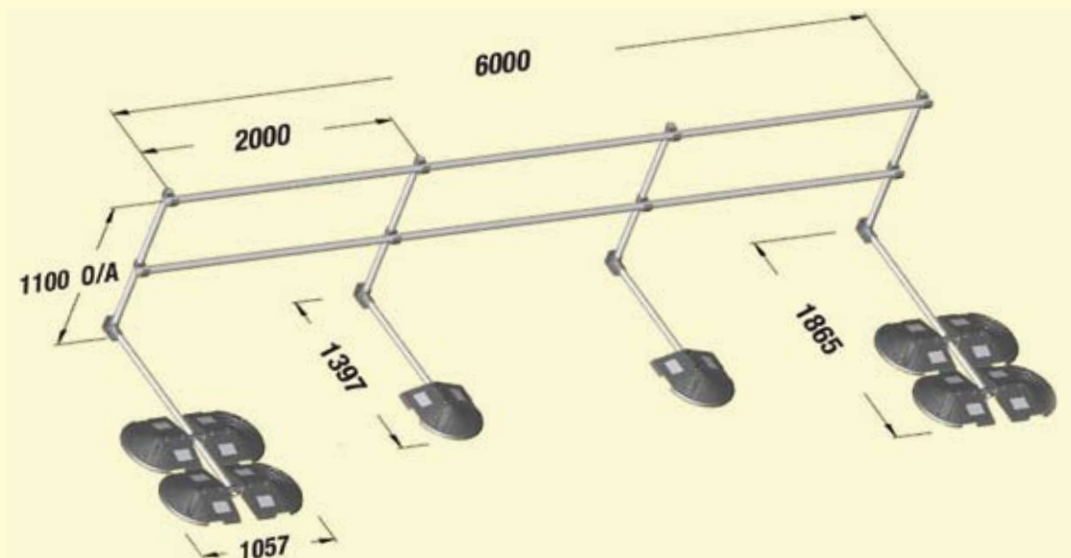

A Typical Unrestrained KeeGuard® Configuration

This is a typical free standing layout, utilising maximum 2.0 metre bays and the required base weight configuration.



Essential Kee Klamp® Fittings Used to Complete a KeeGuard® System

**Kee®
Guard**

<p>14-8</p> 	<p>15-8</p> 	<p>19-8</p> 	<p>61-8</p> 	<p>77-8</p> 
<p>Type 14-8 Straight Coupling is used to connect lengths of tube.</p>	<p>Type 15-8 Elbow is used for 'D' Returns and 90° corners.</p>	<p>Type 19-8 can be used for variable angles and to accommodate slope irregularities.</p>	<p>Type 61-8 Flange is used for wall attachments.</p>	<p>Type 77-8 Plastic Plug is used to cap open tube ends.</p>

Recycled, Easy to Handle PVC Base Weights

The recycled PVC weights used with **KEEGUARD** bring a number of advantages to the system, and particularly make installation quicker and easier, saving both time and money.

- 13.5 kg per weight
- Size: 460 x 500 x 85mm
- Carrying handles moulded into the design
- Available in black as standard. Other colours available by request at extra cost
- Moulded surface to improve grip
- Optional covers for counterweight tube available to minimize trip hazards
- Environmentally friendly
- Made from 100% recycled material in the EU

N. B. To protect asphalt roofs from damage it is recommended that Elastomer tiles, available from **Kee Safety**, are placed under all uprights and counterweights.



KeeGuard® Upright Options

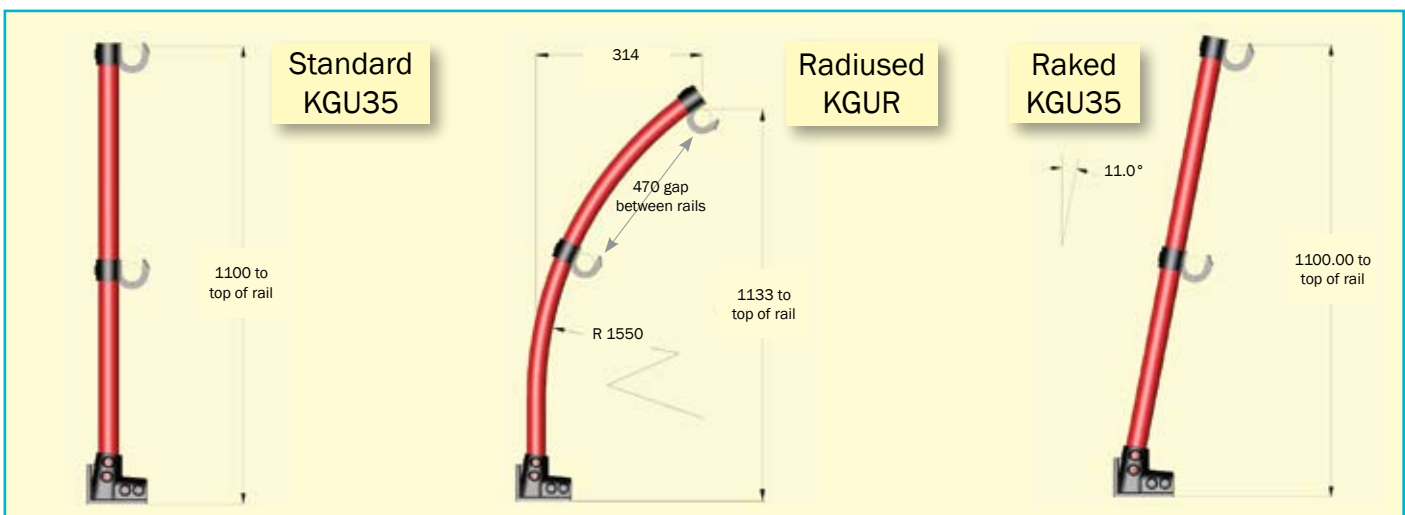

Typical Layout

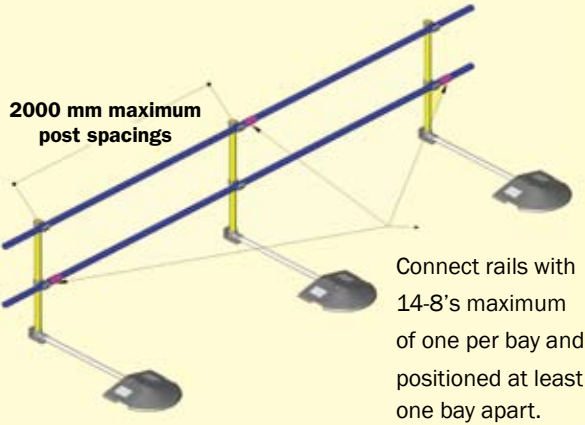

Corner Detail

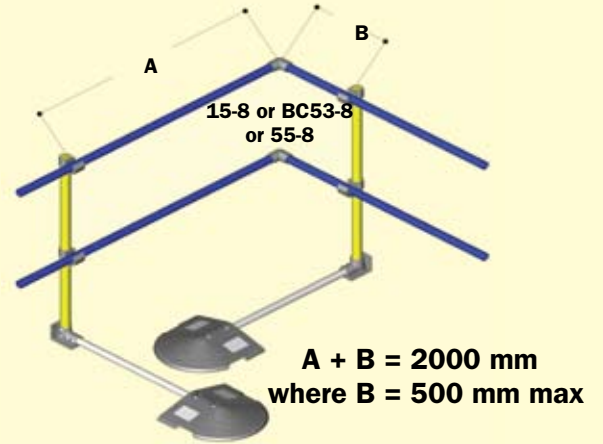

Change in Level Detail

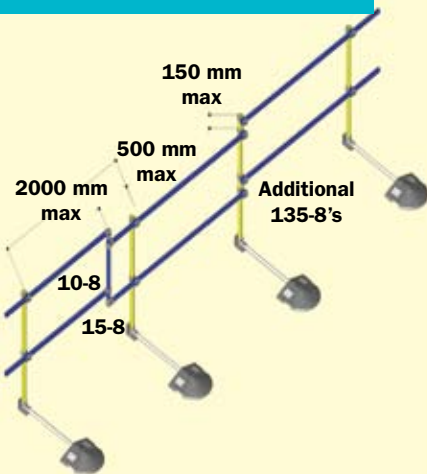

Unrestrained 'D' Return Detail

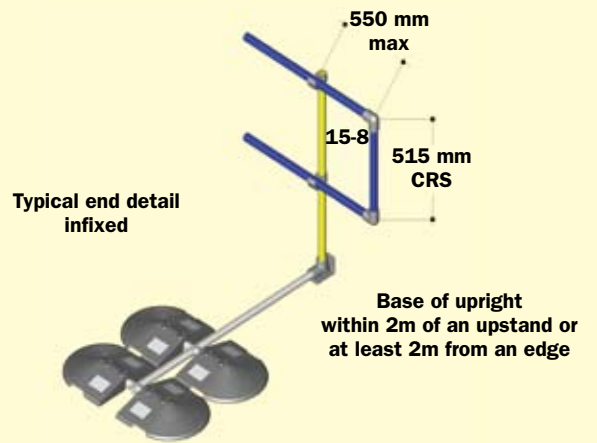

Wall Fix Detail

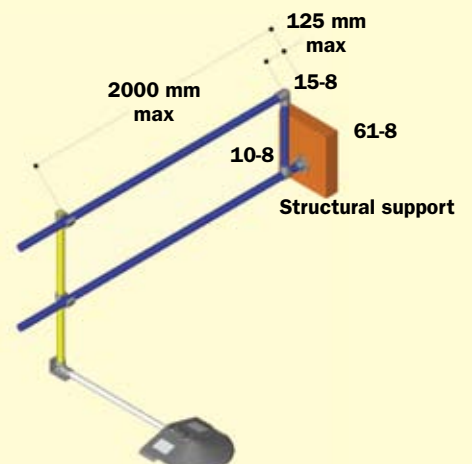
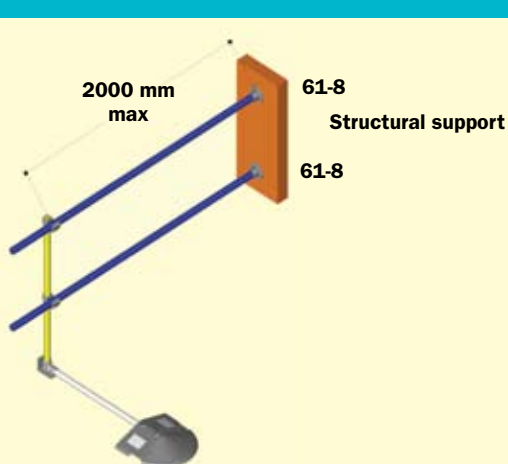

KeeGuard® Counterbalance Configurations

Kee®
Guard

The diagram to the right details a CB1P main counterbalance configuration. When used in restrained situations, these should be placed a maximum distance of 2.2 metres apart in a straight run. Whenever a 90° corner is required, a **KEE KLAMP** fitting 15-8 should be used on each rail. It is essential that an upright is no further than 500mm from the corner and the total length between uprights around the corner is no greater than 2 metres. In a straight run, lengths of handrail are connected together using a **KEE KLAMP** fitting 14-8.

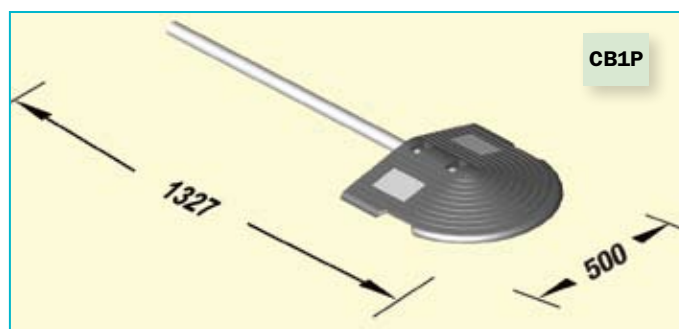

The diagram to the left shows a CB2P counterbalance configuration, for use on free ends when the system has secondary restraint available. Reducing the bay size further can reduce the weight requirement to 1.

The diagram on the right shows an end of run assembly in the CB4P configuration, for use in unrestrained applications. This should be used for end uprights when there is no tie in to the building and at the end of a run that exceeds 6 metres in length. For runs of less than 6 metres, please contact our technical team for advice.



Collective Protection Accessories

Kee®
Safety



Unique design does not require any drilling, a slot on the back of the toeboard accepts a bolt head which prevents the bolt from spinning during assembly. Upright fixings and splice kits for corners and straight sections are also available.

Toeboard can be installed directly to the KGU upright assembly or by using a TB3 saddle bracket direct to the upright.

Required when there is no upstand beneath or in front of a guard rail to protect users or equipment below from falling objects.



To allow compliance with the EN14122-3 requirement for a self closing gate Kee Safety offers a Standard Lockable Gate kit.

It incorporates uprights and an adjustable spring mechanism to control the speed of the gate closure, available in left or right hand options.

RH product code: TCG-1, LH product code: TCG2.

In addition the following KEE KLAMP fittings 4 x 135-8 and 2 x 130-875 are required for each gate ordered plus the appropriate free end counterweight assemblies.

KeeGuard® Free End Counterbalance Details

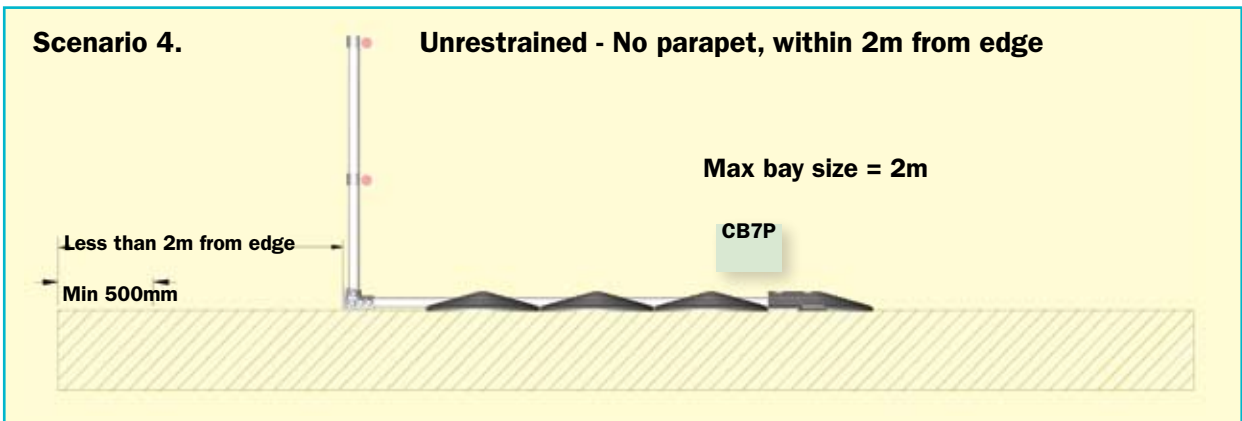
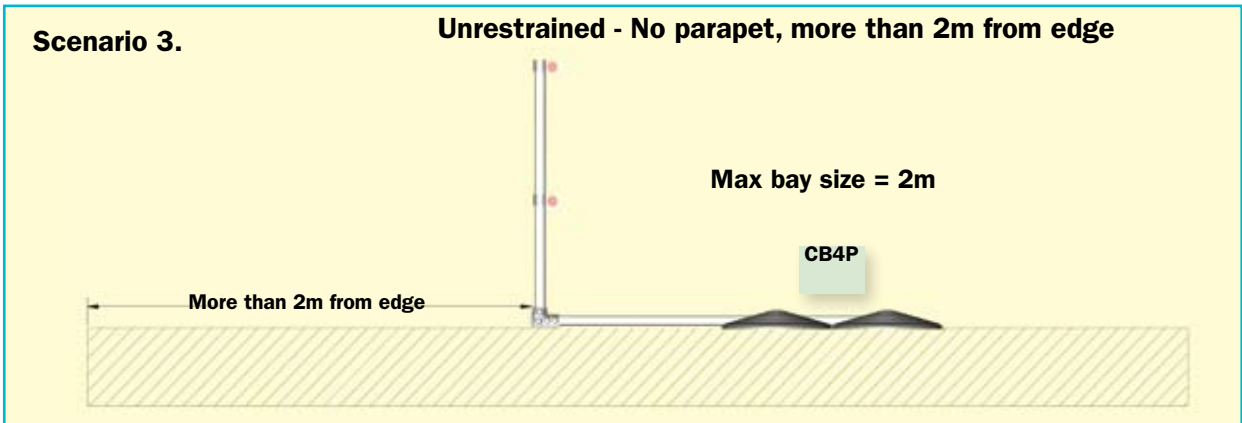
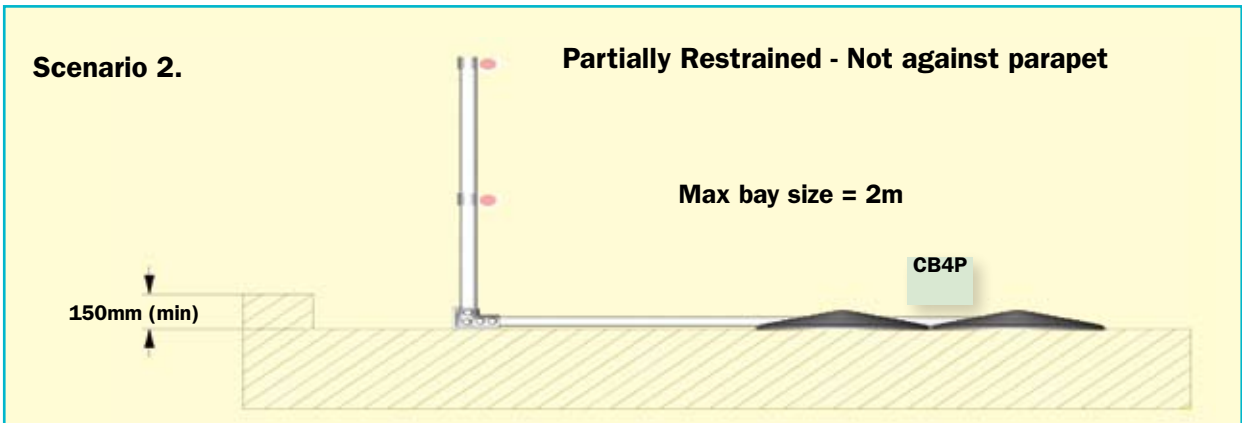

Aluminium Free Standing Roof Edge Protection

**KeeGuard®
Lite**

KEEGUARD Lite is the Aluminium safety solution for free standing roof edge protection, a lightweight alternative to the standard **KEEGUARD** system.

KEEGUARD Lite is supplied in prefabricated kit form, with the uprights, rails and fittings manufactured in Aluminium, grub screws supplied in Stainless Steel and recycled PVC base weights. The lightweight system can be installed with minimal effort, thus saving time and money during on-site installation.



KeeGuard® Lite for Use when Secondary Restraint is Available

KEEGUARD Lite can be used where secondary restraint, such as a parapet wall (minimum height 150mm) is available.

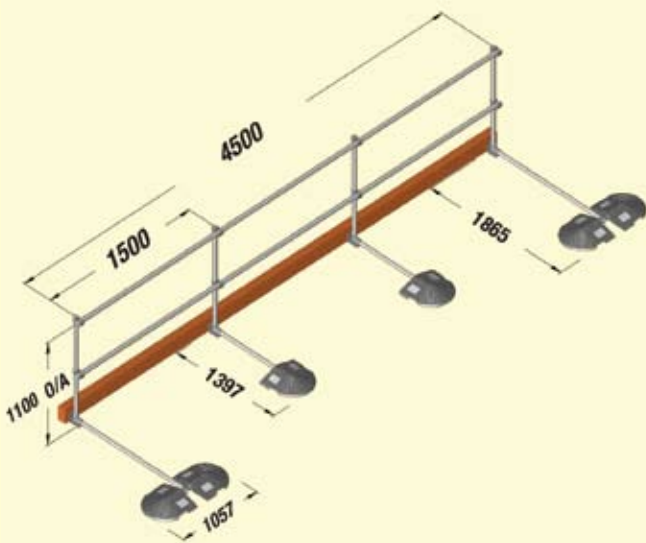

Features

- Aluminium rails and uprights
- Modular system supplied in prefabricated kit form
- Recycled, easy to handle PVC base weights
- Complies with EN 14122 pt.3
- Uses Size 7 (horizontal) and 8 (vertical) tube with bay size a maximum 1.5 metres
- Independently tested at APAVE
- Available for standard, radiused and raked uprights.

Benefits

- Safe, reliable and versatile collective fall protection solution
- Savings in installation time and cost
- Does not penetrate the roof fabric
- Lightweight and corrosion resistant
- Aesthetically attractive
- Minimal long term maintenance keeps on going costs down
- Can be colour coated if required.

Essential Kee Lite® Fittings Used to Complete a KeeGuard® Lite System

L14-7



Type L14-7 Straight Coupling is used to connect lengths of tube.

L15-7



Type L15-7 Elbow is used for 'D' Returns and 90° corners.

L19-7



Type L19-7 can be used for variable angles and to accommodate slope irregularities.

L61-7



Type L61-7 Flange is used for wall attachments.

77-8



Type 77-8 Plastic Plug is used to cap open tube ends.

Free Standing Folding Roof Edge Protection

When collective protection is the preferred method of providing a safe working environment but it is not desirable to have railings permanently visible on the roofline of a building, **KEEGUARD** Foldshield provides an ideal solution.

Designed for use on slopes up to 10 degrees, this folding system is suitable for use on asphalt, concrete, mineral felt or PVC sheet covered roofs and complies with the requirements of EN 13374.

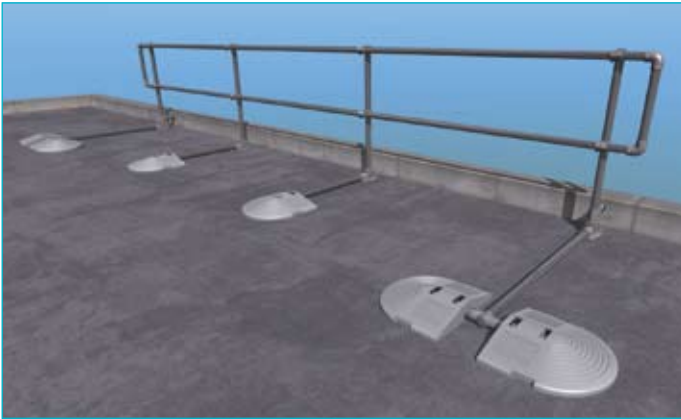

Utilising a hinged version of the standard **KEEGUARD** base fitting, shown below, the guardrail can easily be lifted into place when work is in progress and then quickly folded back down when finished.

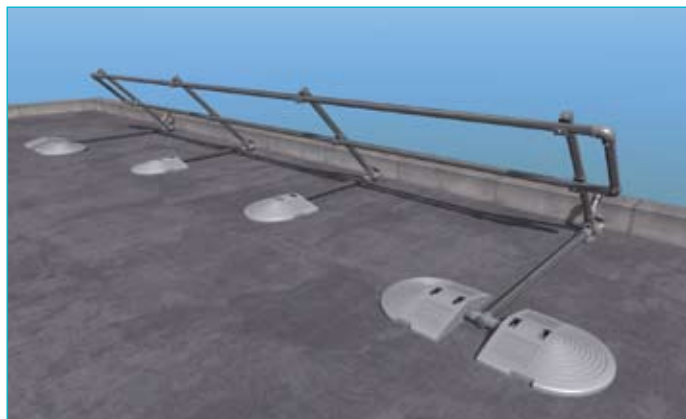

KEEGUARD Foldshield offers all the flexibility of standard **KEEGUARD** allowing continuous runs, fixed ends, corners, changes in direction etc, or can be installed in 6m sections with 'D' returns (as illustrated) to enable it to be folded quickly and simply.

A simple locking pin is all that needs to be removed from the fitting to allow it to pivot.

Two people can easily raise or fold down a standard section (max length 6.4m) of guardrail. To minimise the weight of a section **KEEGUARD** Foldshield is also available in a configuration to allow aluminium mid and top rails.

With a maximum bay size of 2 metres it can be used in both restrained and unrestrained applications.

In order to use the folding fitting in a restrained situation, an additional support prop (shown on the next page) is added to the uprights at six metre intervals to allow sufficient room for the fitting to pivot. A minimum roof up-stand of 250mm is required.



Features

- Folds down when not in use
- Main fitting can only pivot in one direction
- System can be raised and lowered in sections
- Complies to EN 13374.

Benefits

- Does not spoil building aesthetics
- No possibility of the guardrail folding the wrong way
- Saves time and increases flexibility .

An Additional Support Prop



KFU2

A Typical KeeGuard® Foldshield Restrained Configuration

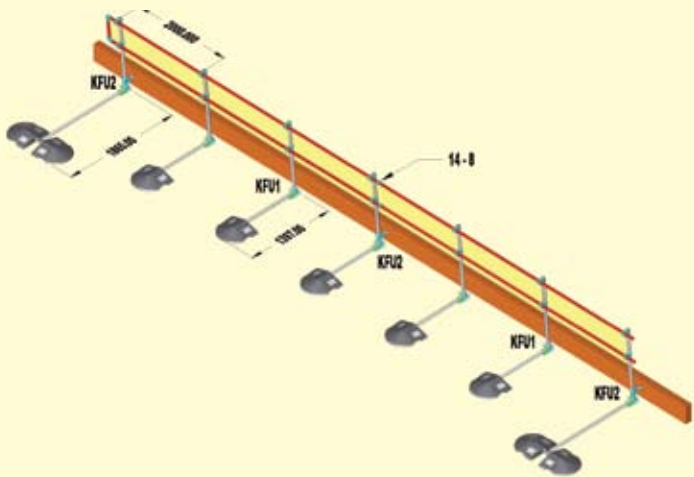

Roof Edge Protection for Standing Seam and Metal Profile Roofs

KEEGUARD Topfix provides a simple solution when collective protection is the preferred safety option for metal profile and standing seam roofs up to 45 degree pitch.

The specially designed powder coated base plate, which incorporates multiple fixing centres, allows installation to a wide range of popular roofs. Being an 'off the shelf' product, specification is simpler and it also removes the need to fabricate a different solution for each site, minimising site visits and down time.

Base plates for standing seam roofs are fixed using non-penetrative 2-part clamps and metal profile roofs are fixed with minimal penetrations using rivets and butyl sealing strip to maintain the roof's integrity.



Being part of the **KEEGUARD** range **KEEGUARD** Topfix allows for fast installation using pre-assembled uprights and open cup fittings and easily accommodates ridges, valleys, corners, changes in level and self closing gates etc. using standard **KEE KLAMP** fittings.

The standard upright base fitting allows for 0-11 degree vertical adjustment and four fixing holes in the base plate allow it to be used in the most beneficial plane to suit the roof profile.

Available in both galvanised steel and aluminium finish.

Complies with the test requirements of BS EN 14122 part 3 and BS EN 13374 Class A, bay sizes for galvanised EN 14122 are 2.5m (1.75m end bays).

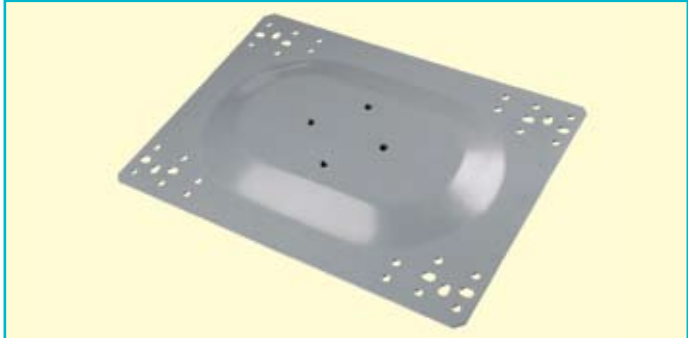

Fixing centres for standing seam roofs: 305, 400 and 500mm.

Fixing centres for trapezoidal profile roof panels: 310, 333, 400 and 500mm.

Features

- Suits a wide range of metal profile and standing seam roofs
- Modular prefabricated 'off the shelf' system
- Galvanised or Aluminium options
- Complies with the test requirements of BS EN 14122 part 3 and EN 13374 Class A.

Benefits

- A collective protection solution for metal roofs
- Easier specification means less site visits
- Fast installation, saving time and money
- Non-penetrative solution for standing seam roofs
- Watertight fixings for metal profile roofs.



A Typical KeeGuard[®] Topfix Layout

